

March 31, 1970

C. MOESLY

3,503,358

SELF-STABILIZING BOAT HULL

Filed Oct. 29, 1968

2 Sheets-Sheet 1

FIG. 1

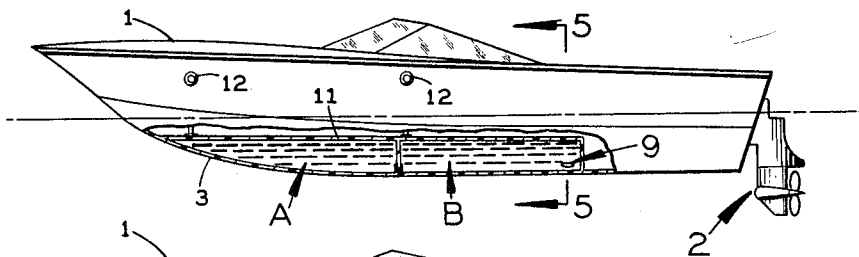

FIG. 2

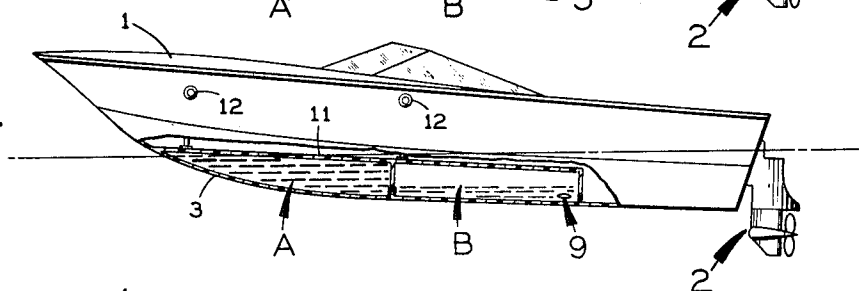

FIG. 3

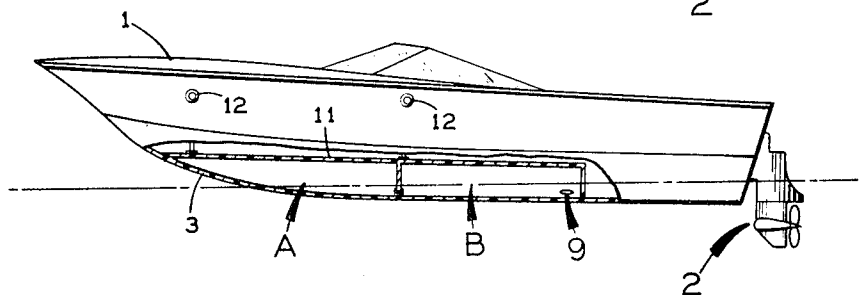

FIG. 4

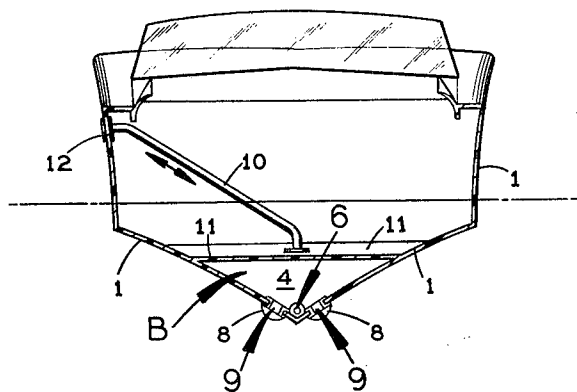
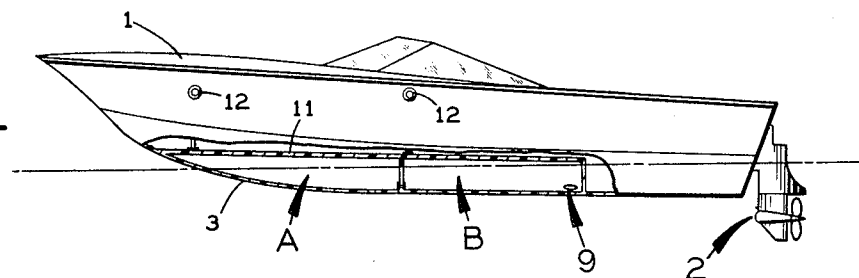

FIG. 5

INVENTOR.
CARL MOESLY

BY
Gregory J. Anderson

March 31, 1970

C. MOESLY

3,503,358

SELF-STABILIZING BOAT HULL

Filed Oct. 29, 1968

2 Sheets-Sheet 2

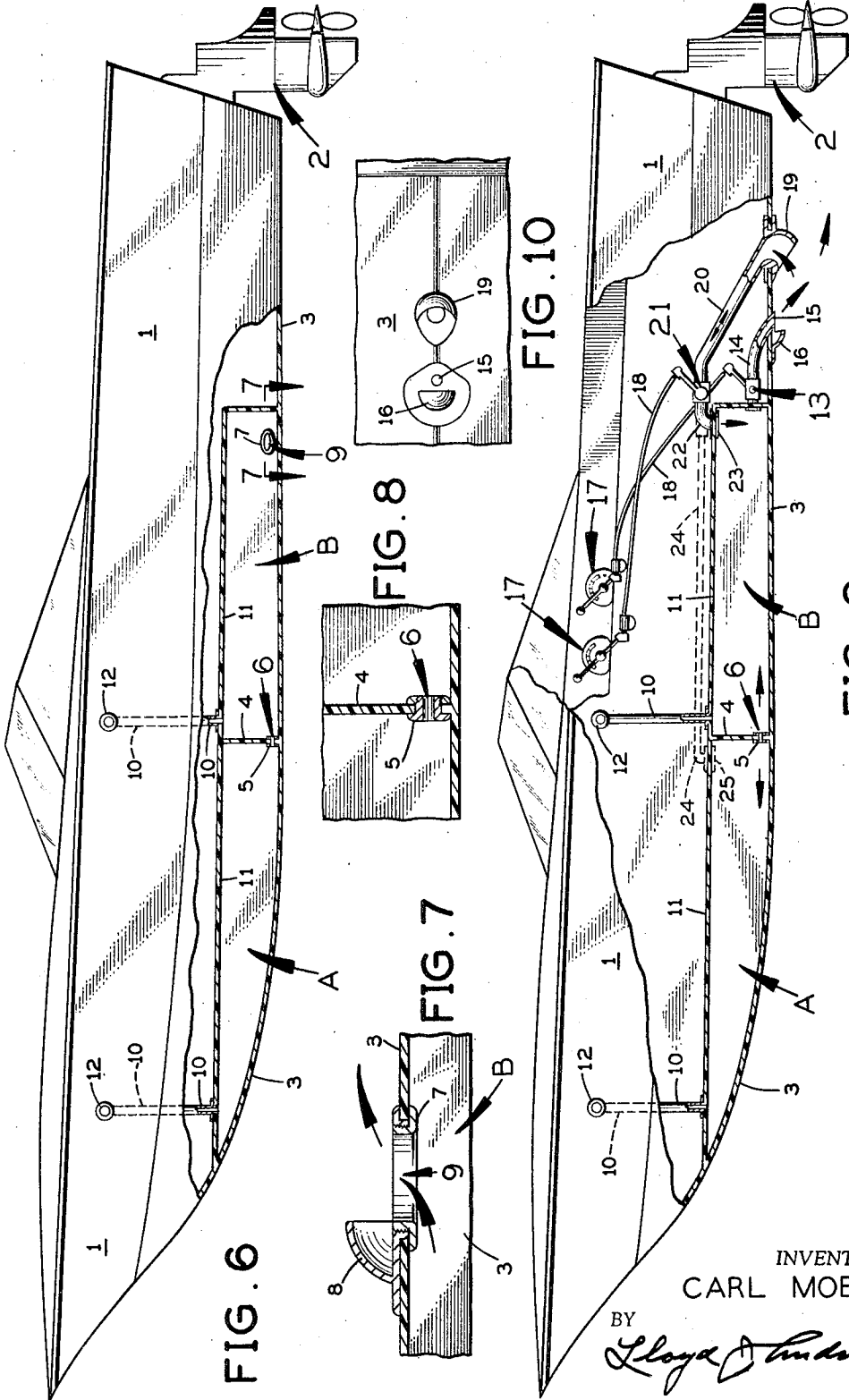

INVENTOR.
CARL MOESLY

BY
Lloyd J. Anderson

1

2

3,503,358

SELF-STABILIZING BOAT HULL

Carl Moesly, 6041 SW. 102nd St., Miami, Fla. 33143

Filed Oct. 29, 1968, Ser. No. 771,483

Int. Cl. B63b 43/06

U.S. Cl. 114—125

6 Claims

ABSTRACT OF THE DISCLOSURE

A boat hull having a longitudinal enclosed tunnel directly above the keel thereof with a transverse bulkhead approximately central of the tunnel forming two ballast compartments with a metering orifice in the bulkhead. An additional orifice opening through the hull enters the rear compartment for flooding both compartments when the boat is at rest or at slow speeds, and for first draining the rear compartment and sequentially draining the forward compartment through the metering orifice for stabilizing the attitude of the boat when accelerated to a planing position.

This invention relates in general to power boats having self flooding compartments for predetermined stabilizing purposes.

Prior hulls having longitudinal tunnels along the keel were satisfactory for stabilizing deep V hulls when at rest; however, during the first forward movement of the boat the water would rapidly flow rearward and escape through a port provided and cause the boat to be unstable and assume a high bow attitude prior to assuming its normal planing position.

This undesirable condition was partially corrected by the use of a manually controlled valve at the rear of the tunnel, which required skilled manual adjustment while accelerating following rest or slow speed operation.

The above objections and disadvantages are overcome in the present invention by the provision of a multi-stage longitudinal tunnel which may be entirely automatic in its operation by stabilizing a deep V hull when at rest, as well as permitting a selected predetermined discharge of rear and forward longitudinal compartments, thus permitting the hull to accelerate to a planing position at a predetermined speed without instability and maintaining all of the well known advantages of a deep V hull, which construction is a principal object of the invention.

Another object of the invention is the provision of a longitudinal ballast compartment in a boat hull symmetrical with the keel thereof including a transverse partition therein separating said compartment into forward and aft portions with a metering orifice through the partition and a fill and empty orifice through the hull into the aft compartment for stabilizing the hull when at rest and through an automatic ballast emptying cycle to a planing position of the hull.

These and other objects and advantages in two embodiments of the invention are described and shown in the following specification and drawings, in which:

FIG. 1 is a side elevation of the boat in rest position with a portion of the hull broken away, showing full water ballast in the hull.

FIG. 2 is the same as FIG. 1 with the boat shown at slow speed with partial water ballast in the hull.

FIG. 3 is the same as FIG. 1 with the boat shown accelerated to a plane speed with ballast water drained from the hull.

FIG. 4 illustrates the position of the boat at rest with no ballast in the hull.

FIG. 5 is a cross sectional end elevation taken through section line 5—5, FIG. 1.

FIG. 6 is an enlarged view of the boat shown in FIG.

1 with a portion broken away, showing the water ballast compartments.

FIG. 7 is an enlarged fragmentary view taken through section line 7—7, FIG. 6.

FIG. 8 is an enlarged fragmentary cross sectional view showing an orifice in the ballast partition shown in FIG. 6.

FIG. 9 is the same as FIG. 6 with manual adjustable ballast controls.

FIG. 10 is a fragmentary bottom plan view of the ballast inlet and outlet orifices shown in FIG. 9.

Referring to FIG. 6, the boat 1 is a typical small to medium size craft, driven by power means 2, shown in part with a pair of longitudinal ballast compartments A and B central of the center line or keel 3 and having a transverse bulkhead 4 therebetween with an orifice means 5 forming a metering port 6 between said compartments through the lower portion of the bulkhead 4. The rear compartment is provided with a rear transverse partition and an open port means 7 in each side of the hull near the keel, better shown in FIG. 7, in which a cowl 8 is provided for inducing water from the ballast B out of the hull through orifices 9 when the boat is moving forward, as indicated by arrows.

It is to be noted the rear compartment B may extend rearward to the transom in certain type hull designs to maintain maximum stability.

There is also provided a conduit 10 through the upper side 11 of each compartment A and B, each of which terminates high through the freeboard of the hull in air orifice 12, in order that air may enter the conduits and flow therethrough and permit the unrestricted filling and discharge of water to and from compartments A and B.

The foregoing construction relates to a ballast system entirely automatic in operation which will be hereinafter described.

Referring to FIG. 9, a ballast system for the manual control of the ballast water in compartments A and B is provided by means of an outlet valve 13, of well known construction, having an outlet conduit 14, terminating in an orifice means 15 through the hull having a cowl 16. The valve is controlled by a well known manual quadrant control assembly 17 connected to the valve assembly 13 by a flexible cable 18. The water inlet is in the form of a scoop 19, also through the lower portion of the hull, connected by a conduit 20 to a second valve assembly 21 with an elbow 22 connected to an orifice means 23 through the upper side 11 of the compartment, as shown. A second well known quadrant assembly 17 is connected by another cable 18 to the control arm of the valve assembly 21.

It is to be noted that the outlet valve assembly 21 may be connected to the ballast compartments by two different constructions; one which permits both compartments to be filled simultaneously requires the elbow 22 in FIG. 9 to be changed to a T and a conduit 24, shown in broken lines, running from the T to the forward compartment through an orifice means 25.

A second construction would eliminate the elbow 22 and extend the conduit 24 from conduit 20 to orifice means 25 only, for filling the forward compartment first and permitting the rear compartment to fill through orifice means 5.

Thus it is apparent that when the boat is moving forward and the valve assembly 21 is open and the valve assembly 13 is closed, water will flow upward through conduit 20 and ultimately fill the compartments A and B with water, which establishes the maximum stabilization of the hull at rest and at low speeds. When the valve assembly 21 is closed and the valve assembly 13 is open, and the boat is accelerated in a forward direction, the ballast water in compartment B will first flow through

conduit 14 and out of orifice means 15. Immediately following the emptying of compartment B the water in compartment A will flow through the partition metering port 6 and ultimately through conduit 14, which will occur when the boat has achieved sufficient speed for planing.

The automatic operation is illustrated by referring to FIGS. 1-5. FIG. 1 illustrates a typical deep V boat hull and the horizontal broken line represents the water level with respect to the boat when compartments A and B are flooded with water, for providing lateral stability when at rest or slow forward speed.

FIG. 2 illustrates the relation of the water line to the hull during forward acceleration of the boat whereby the water in compartment B will empty rapidly through orifices 9-9 whereas the water in compartment A will drain through metering orifice 6 at a slower rate and prevent the bow of the boat from tipping upward.

When the water in compartment A has flowed through compartment B and from orifices 9 then the boat will assume a planing position without loss of stability.

FIG. 4 illustrates the relation of the water line to the boat in the event compartments A and B are empty, which would result in lateral instability.

FIG. 5 illustrates the conduit 10 for providing free movement of air to and from each compartment for rapid filling and draining thereof.

It is apparent that the manual operation of the ballast is useful for obtaining certain predetermined performance specifications of the boat, and referring to FIGS. 9 and 10, the manual modification controls are clearly shown.

The rear compartment B may be selectively emptied by a valve assembly 13, which connects by conduit to orifice means 15, the forward end of which is surrounded by a cowl 16 to aid suction when the boat is moving forward, as illustrated in FIG. 7.

The valve assembly 13 is operated by a well known control quadrant assembly 17, through the medium of a flexible cable 18.

A scoop 19, also shown in FIG. 10, is connected by a conduit to a valve assembly 21 and then through an elbow 22 to an upper rear orifice means 23 in compartment B. The valve assembly 21 is operated by another selective quadrant assembly 17. It is now apparent from FIG. 9 that selective amounts of water may be sequentially discharged from compartments A and B while the boat is underway.

It is also to be noted that the compartments B and A may be selectively filled by the action of the scoop 19 while the boat is underway and under the control of the valve assembly 21.

This invention also comprehends modifications in the above construction within the teaching and features described.

Having described my invention, I claim:

1. A power boat hull having like freeboard sides convergent to and along a longitudinal bottom center line comprising a substantially horizontal partition secured and sealed to opposite inner sides of said hull forming a central tunnel from the bow portion to a transverse rear closure member,

a transverse bulkhead secured in said tunnel to form a forward and a rear water ballast compartment, said bulkhead having a metering orifice of predetermined size through the lower portion thereof, a discharge orifice means through said hull positioned at the lower rear portion of said rear compartment, an independent air vent means through the said upper partition opening into each said compartment where-

by water from the outside of said hull will freely gravitate through said discharge orifice and said metering orifice and fill both compartments to stabilize the normal rest floatation of said hull and whereby the water ballast in said rear and forward compartment will sequentially discharge at predetermined rates through said discharge orifice and said metering orifice respectively when said hull is accelerated forward with automatic stability control into a stable planing position.

2. The construction recited in claim 1 wherein said discharge orifice means comprises a pair of orifice fittings at each side through the hull in the rear portion of said rear compartment and positioned at opposite sides and in close proximity to said center line,

each of said fittings having a rearward faced cowling to form suction from each orifice when said hull is underway.

3. The construction recited in claim 1 wherein said rear closure member is a transverse bulkhead secured at the end of said tunnel a predetermined distance from the stern end of said hull.

4. The construction recited in claim 1 wherein each said air vent means comprises a conduit having one end connected through said horizontal partition and the opposite end connected through the upper portion of a freeboard side of said hull.

5. A power boat hull having like freeboard sides convergent to and along a longitudinal bottom center line comprising a substantially horizontal partition secured and sealed to opposite inner sides of said hull forming a central tunnel from the bow portion to a transverse rear closure member,

a transverse bulkhead secured in said tunnel to form a forward and a rear water ballast compartment, said bulkhead having a metering orifice of predetermined size through the lower portion thereof,

a discharge orifice means in said rear closure member connected by a first conduit means through a water control outlet valve to a cowl type discharge orifice means through said hull,

said water control valve in said conduit adapted and constructed for selective manual operation, a water scoop means through the rear portion of said hull,

one end of a second conduit means connected to said scoop means and connected through a manual water control inlet valve and into an upper portion of said rear compartment whereby the manual selective control of said outlet valve will determine the rate of water discharge from said rear and said forward water ballast compartments respectively and whereby the selective manual operation of said inlet valve will control the flow of water into said rear compartment when said hull is underway.

6. The construction recited in claim 5 including an additional conduit connecting said inlet valve to an upper portion of said forward compartment whereby the selective manual operation of said inlet valve will control the flow of water into both the rear and forward compartments respectively when said hull is underway.

References Cited

UNITED STATES PATENTS

3,186,371 6/1965 Moore 114-125
3,311,083 3/1967 Carlson 114-125 X

TRYGVE M. BLIX, Primary Examiner